

E. F. BEUGLER.
 BARREL HEADING-UP MACHINE.
 APPLICATION FILED DEC. 21, 1911.

1,101,391.

Patented June 23, 1914.

6 SHEETS—SHEET 1.

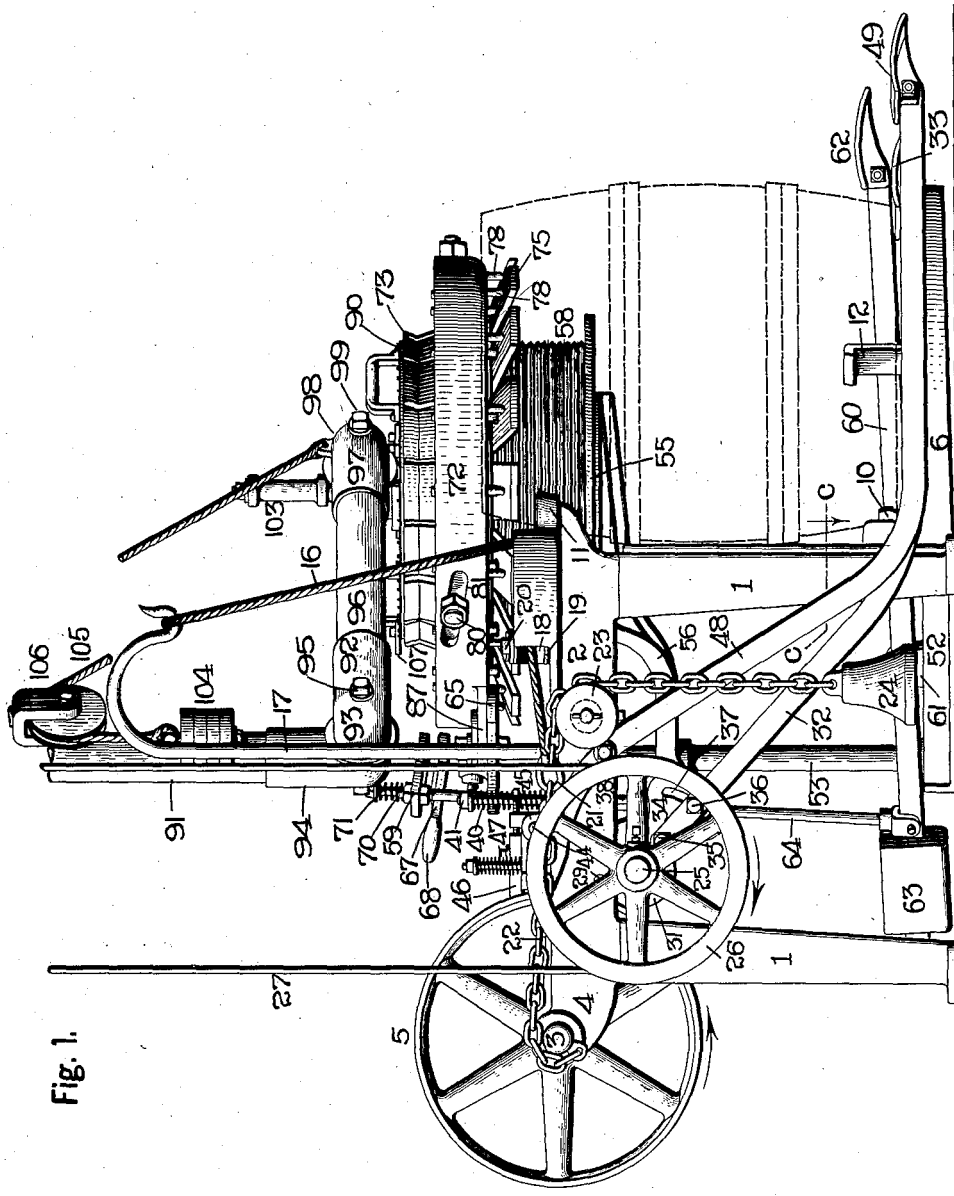

Fig. 1.

Witnesses.
Carl Schramm
George A. Neubauer

Edwin F. Beugler, Inventor.

By *W. J. Sangster* Attorney.

E. F. BEUGLER,
 BARREL HEADING-UP MACHINE.
 APPLICATION FILED DEC. 21, 1911.

Patented June 23, 1914.

6 SHEETS—SHEET 2.

1,101,391.

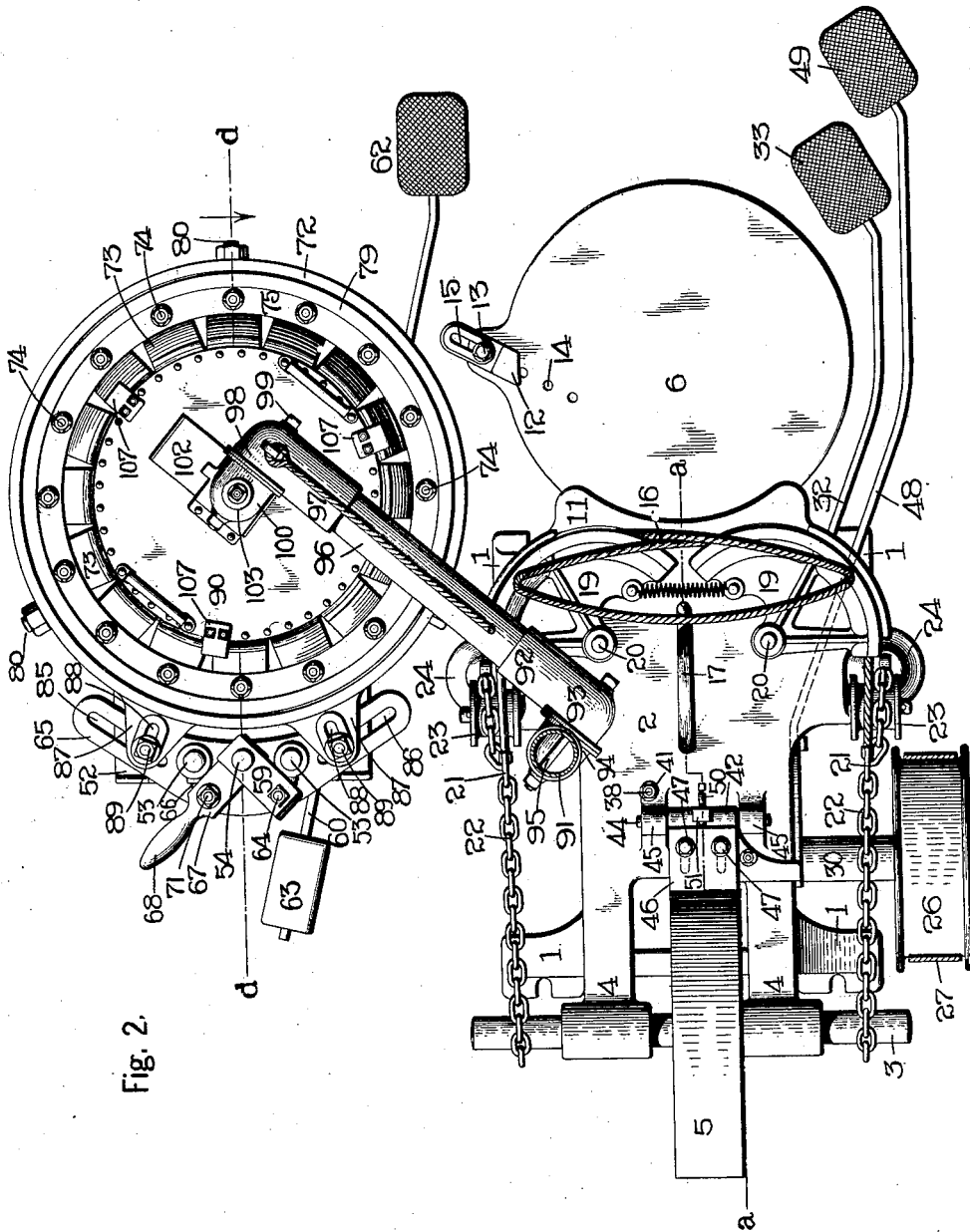

Fig. 2.

Witnesses.
Carl Schramm
George A. Neubauer

Edwin F. Beugler. Inventor.
 By *[Signature]* Attorney.

E. F. BEUGLER.
 BARREL HEADING-UP MACHINE.
 APPLICATION FILED DEC. 21, 1911.

1,101,391.

Patented June 23, 1914.

6 SHEETS-SHEET 3.

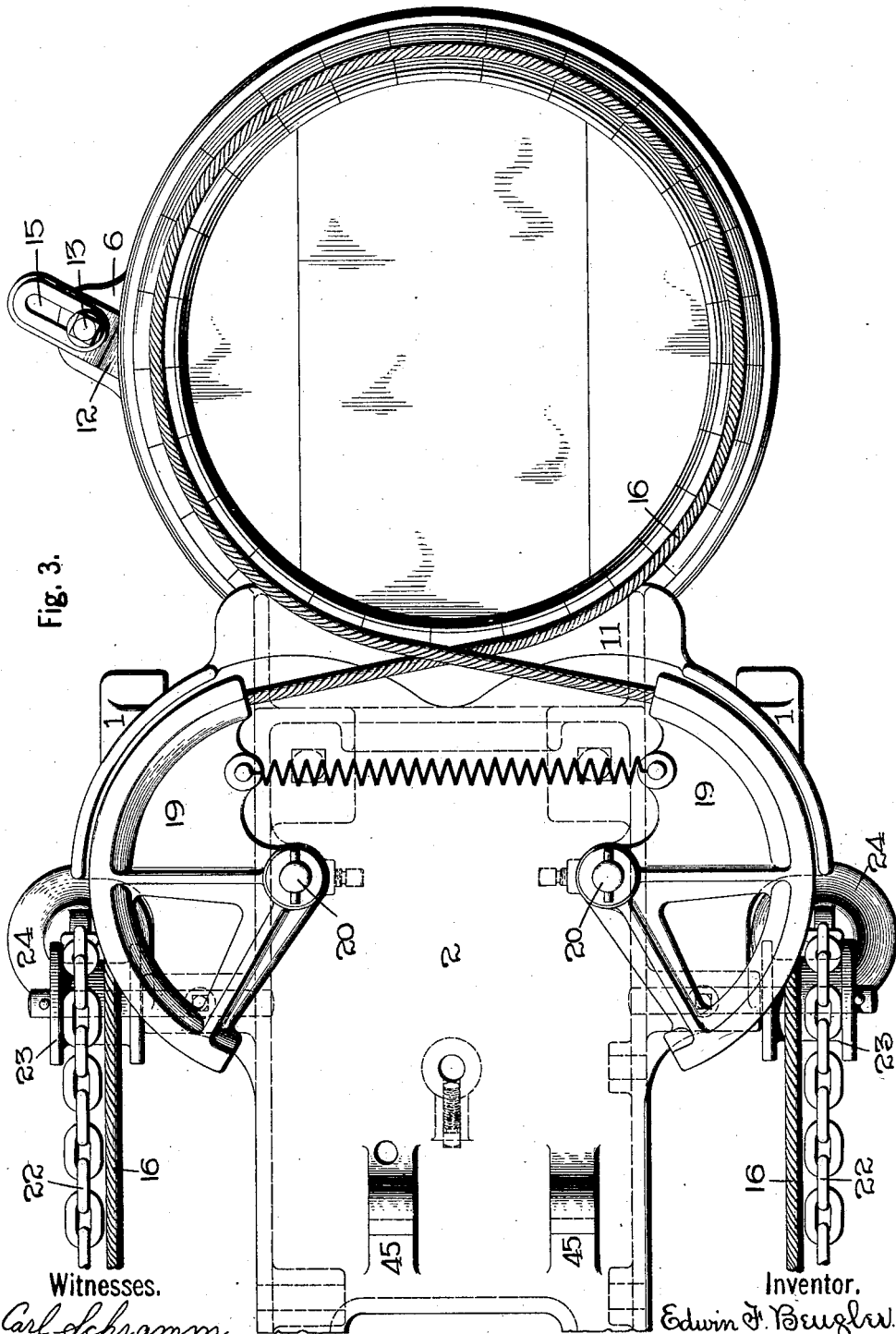

Fig. 3.

Witnesses.
Carl Schramm.
George A. Neubauer.

Inventor.
Edwin F. Beugler.
 By *Al Sangster* Attorney.

E. F. BEUGLER.
 BARREL HEADING-UP MACHINE.
 APPLICATION FILED DEC. 21, 1911.

1,101,391.

Patented June 23, 1914.

6 SHEETS—SHEET 4.

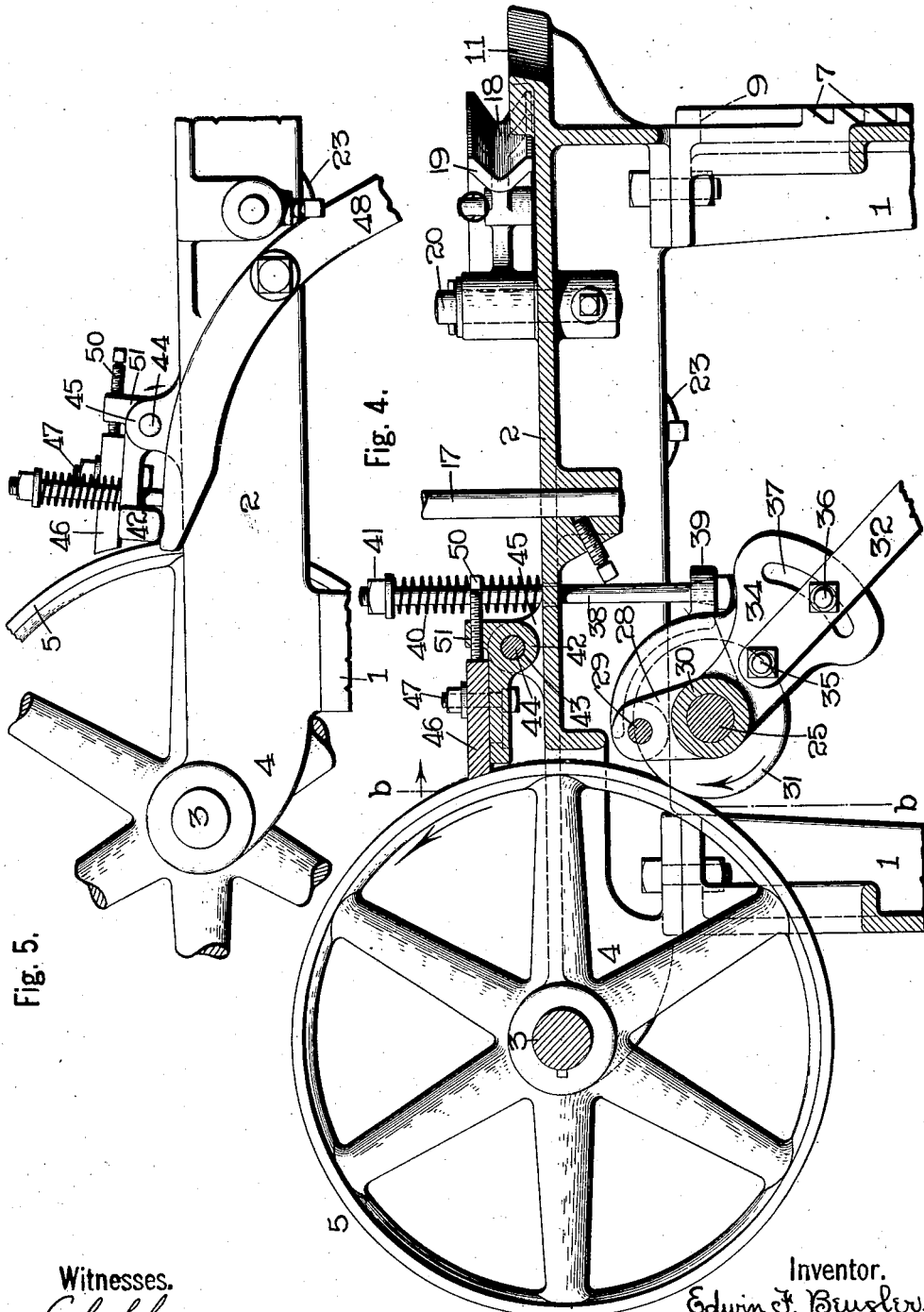

Fig. 5.

Fig. 4.

Witnesses.
Carl Lehmann
George A. Neubauer

Inventor.
Edwin F. Beugler
 By *A. J. Sangster* Attorney.

E. F. BEUGLER.
 BARREL HEADING-UP MACHINE.
 APPLICATION FILED DEC. 21, 1911.

1,101,391.

Patented June 23, 1914.

6 SHEETS—SHEET 5.

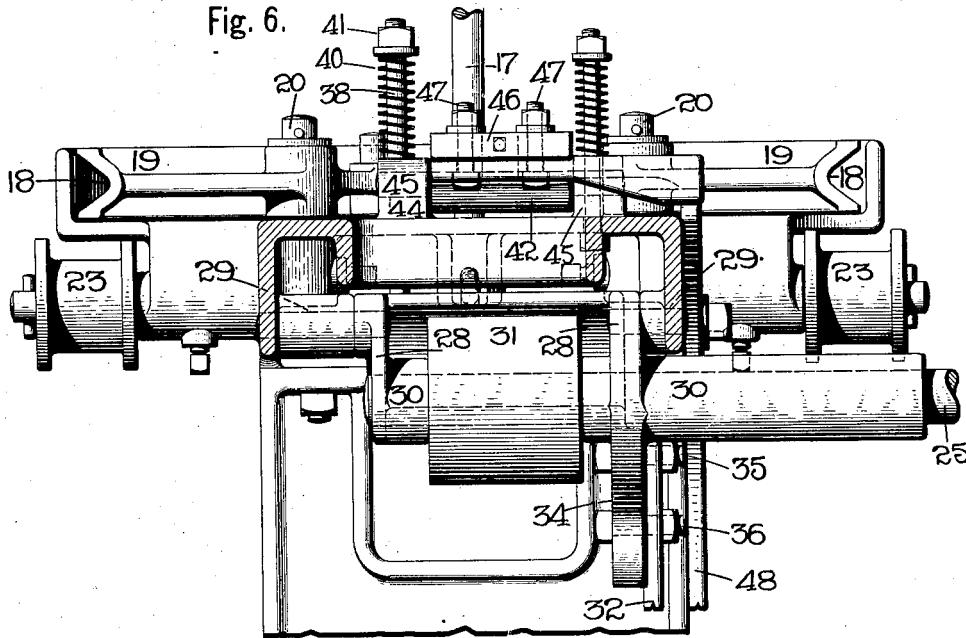
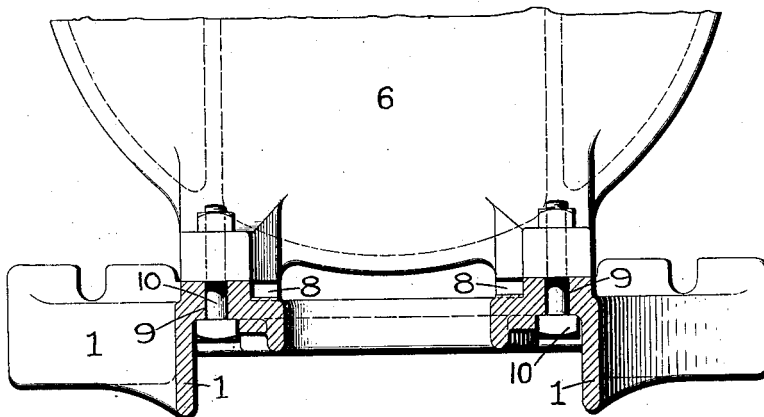

Fig. 7.



Witnesses.
Carl Schramm
George A. Neubauer

Edwin F. Beugler. Inventor.
 By *Alf Sanger* Attorney.

E. F. BEUGLER.
 BARREL HEADING-UP MACHINE.
 APPLICATION FILED DEC. 21, 1911.

1,101,391.

Patented June 23, 1914.

6 SHEETS—SHEET 6.

Fig. 8.

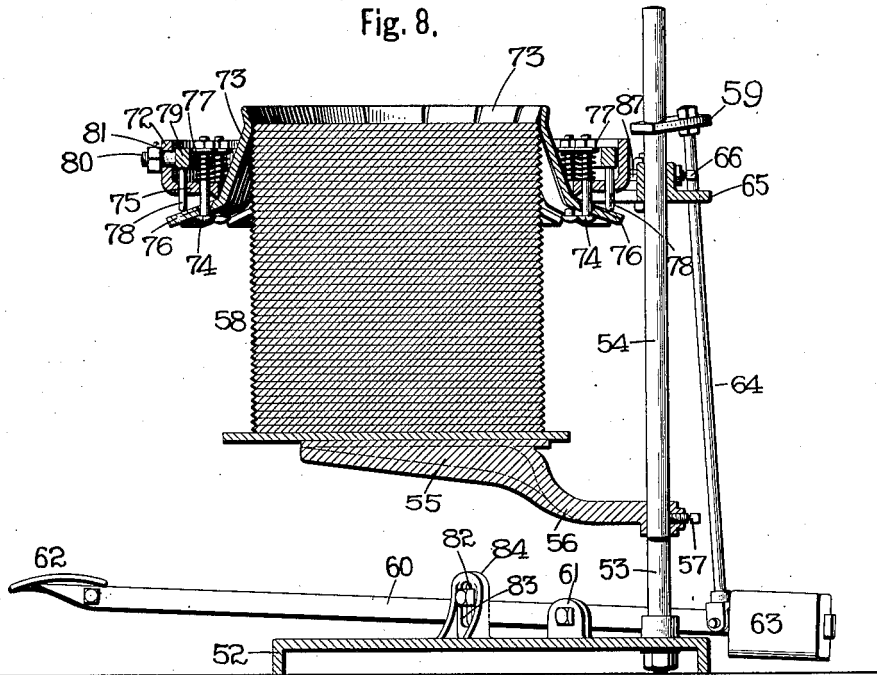

Fig. 9.

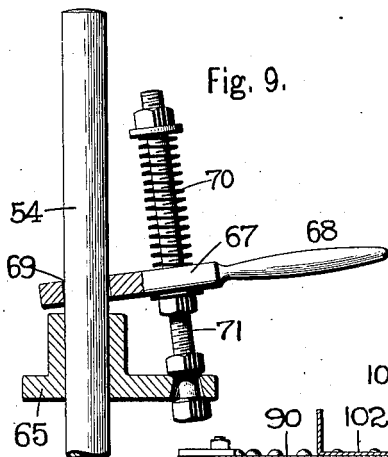
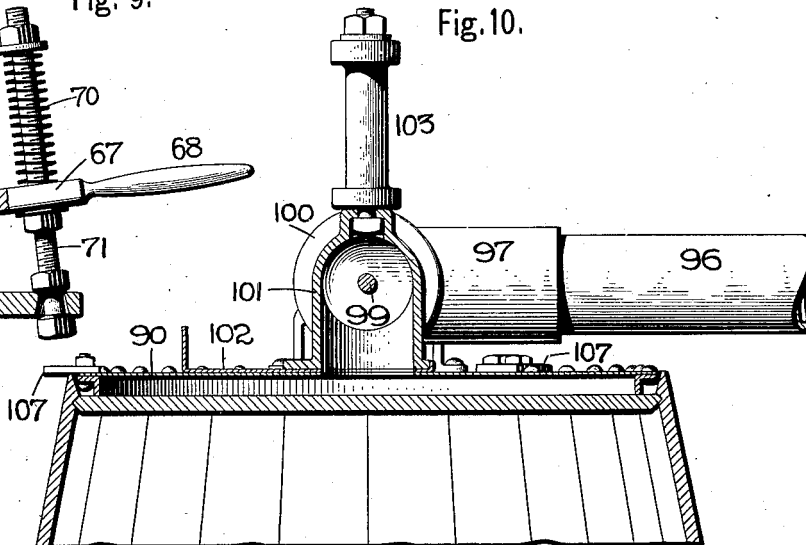

Fig. 10.



Witnesses.

Carl Schramm
George A. Neubauer.

Edwin F. Beugler. Inventor.

By *C. J. Sampson* Attorney.

UNITED STATES PATENT OFFICE.

EDWIN F. BEUGLER, OF BUFFALO, NEW YORK, ASSIGNOR TO E. & B. HOLMES MACHINERY CO., OF BUFFALO, NEW YORK, A CORPORATION OF NEW YORK.

BARREL-HEADING-UP MACHINE.

1,101,391.

Specification of Letters Patent. Patented June 23, 1914.

Application filed December 21, 1911. Serial No. 667,151.

To all whom it may concern:

Be it known that I, EDWIN F. BEUGLER, a citizen of the United States residing at Buffalo, in the county of Erie and State of New York, have invented new and useful Improvements in Barrel-Heading-Up Machines, of which the following is a specification.

This invention relates to improvements in machines for heading up barrels.

One of the features of this invention has reference to a plate for supporting a plurality of barrel heads in superimposed position and manually operated means for raising said plate a distance about equal to the thickness of a barrel head, so that the heads may be successively removed from the plate by a suitable mechanism and carried to and deposited in proper position in the mouth of the barrel.

Another feature has reference to a barrel head centering and supporting device composed of a ring arranged above the barrel supporting plate and provided with a series of spring mounted fingers supported by the ring and arranged in the form of an annulus, through which the barrel heads are successively forced by the elevation of the barrel head supporting plate; said fingers being bent at or near the middle so that the annulus will have outwardly flaring upper and lower portions and a constricted intermediate portion.

Another feature has reference to a pneumatic carrying mechanism for picking up the parts of a barrel head by suction from its supported and centered position in the upper portion of the barrel head supporting ring, and carrying and depositing the same in proper position in the mouth of a barrel so that its surrounding edge will be in horizontal registering position with the chime or groove in the barrel staves.

Another feature has reference to a barrel encircling cable which is adapted to be looped around the upper portion of a barrel arranged in the machine, the novel means for contracting the same around the staves of a barrel to grip and hold the barrel head in the chime or groove of the staves and a brake for locking the staves in their constricted position.

The principal objects of the invention are to quickly and conveniently assemble and center the several parts or pieces comprising

a barrel head, to pick up the same in its assembled condition and carry it to and adjust it in proper position in the mouth of a barrel, and to contract the staves to hold the head parts in place, and to hold said staves in contracted position while the carrying mechanism is detached and removed and the hoops are driven on.

The invention also relates to certain details of construction which will hereinafter be described and perhaps claimed, reference being had to the accompanying drawings, in which a preferred adaptation of the improved machine is illustrated.

Figure 1 is a side elevation of the improved barrel heading up machine, a barrel being shown in dotted lines upon the supporting platform in position to have a head inserted therein. Fig. 2 is a top plan view of the improved barrel heading up machine. Fig. 3 is an enlarged fragmentary top plan view of the improved barrel heading up machine showing a barrel in place upon the supporting platform with a head inserted therein and the staves compressed by the cable ready to have the end hoops driven home. Fig. 4 is an enlarged fragmentary central vertical longitudinal section through the improved barrel heading up machine on line *a-a* Fig. 2 showing the friction pulley in engagement with the wheel on the winding shaft; the cable and chains being omitted. Fig. 5 is a fragmentary side elevation of the machine frame showing the winding shaft and a portion of the friction wheel mounted thereon, the brake being shown in released position to permit the reverse rotation of the friction wheel. Fig. 6 is a transverse vertical section through the portion of the improved barrel heading up machine shown in Fig. 4, the section being taken on line *b-b* in said Fig. 4. Fig. 7 is an enlarged horizontal section through the machine frame on line *c-c*, Fig. 1, showing a fragmentary top plan view of the barrel supporting platform and the manner of adjustably securing it in place. Fig. 8 is a detached central vertical section through the heading feeder of the improved barrel heading up machine, on line *d-d*, Fig. 2. Fig. 9 is an enlarged fragment, partially in section, of the heading feeder, showing the brake for holding the vertically sliding rod of the heading support. Fig. 10 is an enlarged central vertical section through the

suction plate of the pneumatic heading carrier, showing the same holding a barrel head in position within a barrel end with the barrel staves compressed around the same.

5 Referring to the drawings in detail, like numerals designate like parts.

Briefly stated, this improved machine comprises in its organization a frame having a supporting plate or platform upon
10 which a barrel is placed in upright position, a cable arranged to encircle a barrel placed on said supporting plate, means for contracting said cable around the barrel to compress the upper portion of the staves of
15 the same, a supporting plate located at one side of the machine frame upon which a plurality of barrel heads are arranged in superimposed position, a head centering and assembling element in the form of an annu-
20 lus arranged above the supporting plate through which the barrel heads successively pass, and a pneumatic carrying mechanism for picking said barrel heads one by one from the upper portion of the centering and
25 assembling annulus and conveying them to and depositing them in proper position in the mouth of the barrel.

The frame of the machine which will be hereinafter termed the main machine frame
30 consists of the side members or legs, 1, and the horizontal machine plate or bed, 2, which is located and arranged at the top terminals of the side members, 1. A transverse shaft, 3, is journaled in bearings in brackets, 4,
35 located at and projecting rearwardly from the rear of the main machine frame. A friction wheel, 5, is mounted on an intermediate portion of the shaft, 3, being located between the brackets, 4, as shown in Fig. 2.
40 A circular, or approximately circular, plate 6, is bolted to the front of the main frame of the machine and extends horizontally forward from the lower end thereof. The plate is vertically adjustable relatively to
45 the front legs, or members, 1, to accommodate different sizes of barrels.

Referring to Fig. 4, it will be noted that a series of teeth, 7, are formed on the front of its members or legs, and the rear of the
50 plate, 6, is likewise provided with a corresponding series of teeth, 8, which are adapted to lap lock with the teeth, 7, to rigidly hold the plate in its adjusted position. To permit this vertical adjustment of the plate,
55 vertical slots, 9, are formed in the legs, through which the bolts, 10, which fasten the plate to the legs, extend. This plate serves as supporting platform upon which the barrels are placed in upright position
60 and to facilitate centering the barrels on this plate the front portion of the top plate of the main frame to which said plate is bolted is curved to extend approximately in correspondence with the curve of the barrel,
65 as shown in Fig. 2, forming a shoulder

against which the rear side of the barrel contacts when it is placed on the plate 6. This shoulder is indicated in Fig. 2 by the numeral 11.

To additionally assist in centering a bar- 70
rel on the supporting plate, 6, a stop block, 12, is arranged on one side of the plate, being attached to the upper surface of said plate by a bolt, 13, which is fitted through any one of a series of vertical openings, 14, 75
in the plate and a longitudinal slot, 15, in the stop block, as shown in Fig. 2.

A stave compressing mechanism is arranged on the main machine frame and consists of a wire cable, 16, the middle portion 80
of which is adapted to be fitted in an encircling position around a barrel and to be contracted to compress the staves of the same by mechanism connected to its end portion. The stave compressing mechanism 85
is so located and arranged that the cable loop may be bent upward and supported when not in use by being hung on the hooked upper end of a vertical rod, 17, which extends upward from the main ma- 90
chine frame as shown in Fig. 1. The compressing cable extends or loops around the barrel as shown in Fig. 3, and then extends rearwardly through the grooves, 18, in segments, 19, journaled on the upper end of 95
short vertical shafts, 20, carried in the plate or bed, 2, and has its rear ends secured by couplings, 21, to chains, 22. The rear ends of the chain, 22, are connected to and wind upon the shaft, 3, as shown in Fig. 2, and 100
the forward portions of said chain extend over idle grooved pulleys, 23, and are provided at the lower ends with weights, 24, as shown in Fig. 1, which serve to maintain the chain in taut condition and also to unwind 105
it from the shaft, 3. The transverse shaft, 3, is adapted to be rotated from a driving shaft, 25.

Referring to Fig. 5, it will be noted that the shaft, 25, is journaled in swinging bear- 110
ings, the upper ends of which are pivoted to the main frame of the machine. A driving pulley, 26, is mounted on the shaft 25, and is connected by a belt, 27, a section through which is shown in Fig. 2, to any 115
suitable source of power. The swinging bearings in which the shaft, 25, is journaled, comprise arms, 28, which are pivoted at their upper ends to suitable points on the main machine frame by pivots, 29, and have 120
their lower ends shaped to form journals, 30, for the shaft. The friction pulley, 31, which is mounted on the shaft, 25, is adapted to be removed into engagement with the friction wheel, 5, on the transverse shaft, 3, 125
by an angular lever, 32, which is provided at its forward end with a plate, 33, for the foot of the operator. The rear end of the angular lever, 32, is fastened to a crank arm, 34, extending from the swinging bearings, 130

30, by two bolts, 35 and 36. To provide means for adjusting the angular lever relatively to the crank arm, 34, the outer end of the crank arm is widened and provided with a curved slot, 37, through which the bolt, 36, passes, as shown in Fig. 4.

The shaft, 3, is rotated to wind up the chains, 22, and thereby contract the cable, 16, around the barrel by the operator depressing the foot plate, 33 and thus swinging the shaft, 25, so as to bring the friction pulley, 31, into frictional engagement with friction wheel, 5. The friction pulley, 31, is normally held out of contact with the friction wheel, 5, by a vertical rod, 38, which has its lower end passed through a lateral lug, 39, on the swinging bearings, 30, and extends upwardly through the machine bed, 2. A comparatively heavy coiled spring, 40, encircles the upper end of the rod, and is held in place thereon by a washer and nut, 41, see Fig. 4.

A manually controlled brake is mounted on the machine plate or bed, 2, and is adapted to be moved into frictional engagement with the periphery of the friction wheel, 5, as shown in Fig. 4. As shown in said Fig. 4, this brake consists of a metal block, 42, which is provided at one end with an eye, 43, through which a pintle, 44, is fitted to pivot the metal block, 43, to lugs, 45, extending up from the plate or bed, 2 of the main machine frame; a wooden friction block, 46, secured by bolts, 47, to the top surface of the metal block, 42, and an angular lever, 48, the lower forward end of which is provided with a foot plate, 49, and the rear end of which is operatively connected to the metal block, 42. The wooden friction block, 46, is mounted on the metal block, 42, so that it may be adjusted longitudinally thereon, an adjusting screw, 50, being located in a screw threaded opening in a raised portion, 51, extending upward at the front end of the block as shown in Figs. 4 and 5. The rear end edge of the wooden friction block, 46, is adapted to contact with the periphery of the friction wheel, 5, as shown in Fig. 4, and thereby frictionally lock the shaft, 3, against rotation and thus maintain the cable in its contracted compressing condition around a barrel.

A support for a plurality of barrel heads is arranged at one side of the main machine frame and has a base, 52, from which a series of standards extend vertically upward. These standards are preferably three in number and the side standards are rigidly fastened to the base while the center standard is adapted to be vertically adjusted. The side standards will be hereinafter indicated by the numeral 53, and the center standard by the numeral 54. A supporting plate, 55, has an angular extension or arm, 56, which is provided with openings through

which the standards, 53 and 54 pass, said arm, 56, being rigidly secured to the center standard, 54, by a set screw, 57, and being loosely and slidably supported on the side standards, 53.

A plurality of barrel heads are adapted to be arranged in superimposed position on the supporting plate, 55, substantially as indicated by the numeral 58, in Fig. 8, and the said supporting plate is adapted to be elevated by the vertical adjustment of the center standard. The center standard is elevated by means of a lifting plate, 59, which is provided with an opening through which the standard loosely passes. A foot lever, 60, is pivotally mounted on the base, 52, being pivoted to an upwardly projecting lug, 61, at an intermediate point as shown in Fig. 8. A foot plate, 62, is mounted at the forward end of the lever, 60, and a counterweight, 63, is arranged at the rear end of said lever. This foot lever, 62, is operatively connected to the lifting plate, 59, by a connecting rod, 64, the lower end of which is pivoted to the foot lever, and the upper terminal of which is fastened to the lifting plate at one side of the opening through which the center standard passes. A top plate, 65, of curved or angular formation is rigidly mounted on the outer standards, 53, being provided with three openings through two of which the outer standards pass. Set screws, 66, are utilized to rigidly fasten the top plate to the outer standards as shown in Fig. 8.

A plate, 67, is arranged beneath the plate, 59, and serves to frictionally lock the center standard in its position and also as a releasing device being provided with a handle, 68, which is depressed by the operator from the inclined position shown in Fig. 9 to a substantially horizontal position when it is desired to release and drop the center standard. The plate, 67, is normally held in its oblique position on the center standard so that the edges of the opening, 69, through which the standard passes frictionally grip and hold the center standard by a coil spring, 70, mounted on a bolt or bar, 71, which passes through the top plate and the plate, 67, see Fig. 9.

The several parts composing a barrel head are centered by an annular device which is arranged vertically above the barrel head supporting plate and consists of a supporting ring, 72, of angular cross section, as shown in Fig. 8, and a series of fingers or members, 73, which are arranged in annular position within the ring and hung on bolts, 74, which pass loosely through openings in the lower inwardly extending portion or flange, 75, of the supporting ring, and openings, 76, in the lower portion of the fingers or members. Spiral springs 77 are arranged on the upper projecting portions of the

bolts and by their tension serve to maintain the fingers or members in their normal position. The angular fingers or members, 73, rock on the inner extremity of the flange, 75, so that their upper portions will move to enlarge the circumference of the annulus, and thus permit the passage of the barrel heads. The inward movement of the upper portion of the fingers, or members, is limited by a series of vertical pins, 78, which pass through openings in the flange, 75 and bear with their lower ends against the lower portions of the members and their upper ends against a ring, 79. The ring, 79, is supported within the flanged ring, 72, by a series of radial bolts, 80, which pass through slots, 81, in the flanged ring, 72, see Fig. 8, the slots being inclined, as shown in Fig. 1, so that partial rotation of the ring, 79, within the flanged ring, 72, will either move the pins, 78, downward to spread the upper portion of the centering fingers, or permit the springs, 77, on the bolts, 74, to bring the upper portions of the centering fingers or members together and move the lower portions upward thereby pressing the pins, 78, upward.

An adjustable stop is placed on the base which consists of a block, 82, mounted in a vertical slot, 83, in an extension, 84, see Fig. 8, against which the foot lever, 60, strikes to limit its movement. The object of this is to provide means for regulating the length of movement of the central standard to correspond with the thickness of the heads so that but one head will be pushed through the centering device at a time.

The supporting ring, 72, is connected to the curved top plate, 65, by a slotted connection so that it may be adjusted, the top plate, 65, being provided with two slots, 85 and 86, one in each corner, and the supporting ring, 72, with two ears, 87, which project therefrom and are provided with slots, 88. The ring, 72, is fastened to the top plate, 65, by bolts, 89, which are passed through the slots, 88, in the ears, 87. The operation of this portion of the machine is as follows: A number of heads are placed in superimposed position on the supporting plate, 55, as shown in Fig. 8, and the foot lever, 60, is depressed each time it is desired to move another through the annular head centering device. The depressing of the foot lever, 60, moves the connecting rod, 64, upward which raises the lifting plate, 59, turning said lifting plate at an incline to the center standard so that said standard is frictionally gripped between the edges of the opening through which the center standard passes. This in turn elevates the center standard and moves the support and the superimposed heads upward.

The several parts of the top barrel head after they have been forced through the

lower portion of the centering annulus are picked up and carried to and deposited in position in the mouth of a barrel by pneumatic mechanism, which is constructed preferably as follows:—A suction plate, 90, is arranged at the outer terminal of a tubular air conductor which is formed in pivotally jointed and telescopic sections so constructed that the suction plate has an inward range of movement and can be turned upward, swung horizontally or moved inwardly or outwardly. The tubular air conductor consists of an inner vertical tube, 91, having its upper end connected to a tube or pipe extending from a suitable source of air suction, a short horizontal tube 92 having a bend or elbow 93 on one side which is pivotally fastened to a similar side bend at the lower end of a short vertical tube 94 fitted on the lower end of the vertical tube 91 by a bolt 95 which passes through both bends, an intermediate horizontal tube 96 having its inner end snugly but slidably telescoping in the end of the tube 92 opposite the bend 93, a short horizontal tube 97 into which the opposite end of the tube 96 snugly but slidably telescopes, said tube 97 also having a side bend or elbow 98 at its outer end which is pivotally fastened by a bolt 99 to a corresponding bend 100 on the upper end of an outer vertical tube 101 which extends upward from the center of the suction plate to which its lower end is fastened. The side bends or elbows are flanged and the flanges are held in close and snug contact by the fastening bolt to prevent the entrance of air as much as possible. The suction plate, 90, is provided with an opening registering with the opening in the short tube, 101, which can be closed when desired by the slide plate, 102. A handle, 103, projects vertically upward from the short vertical tube, 101, and is adapted to be grasped by the operator in moving the suction plate. The tubular air conductor is held in any position in which it may be adjusted by a counterweight, 104, hung on one end of a cable, 105, which passes on a pulley, 106, and is fastened at its opposite end to the tubular air conductor. The suction plate is so supported by the tubes that it can be given a limited universal movement and is provided with a suitable number of outwardly extending projections, 107, which contact with and rest upon the top edge of the staves of a barrel when the suction plate is in position over the barrel and thus support a barrel head in proper and exact position in the croze of the staves, as shown in Fig. 10.

In brief, the operation of the entire machine is as follows: A barrel being placed in position, the stave compressing rope is placed around the same, a head is picked up by the suction plate and swung by the

operator over in position in the mouth of the barrel, the compressing rope is drawn taut around the barrel, the suction plate is swung back in position to pick up another head, and finally the upper hoops are forced into place one by one by the hoop drivers.

I claim:—

1. The combination with heading mechanism, and a support for barrel heads, of pneumatic barrel head carrying mechanism adapted to remove a barrel head from the barrel head support and deposit it in proper position in the mouth of a barrel comprising an inner vertical tube having its upper end connected to a suitable source of air suction and provided with a side bend or elbow at its lower end, an inner short horizontal tube having a similar side bend or elbow at its inner end and pivotally bolted to the side bend or elbow of the vertical tube, an intermediate horizontal tube which is straight throughout and has its inner portion in slidable telescopic connection with the outer portion of the inner short horizontal tube, an outer short horizontal tube provided at its outer end with a side bend or elbow and having its inner portion in slidable telescopic connection with the outer portion of the straight intermediate horizontal tube, an outer short vertical tube having a side bend or elbow at its upper end pivotally bolted to the side bend or elbow of the outer short horizontal tube, and a suction plate attached to the lower end of the outer short vertical tube.

2. The combination with heading mechanism, and a support for barrel heads, of pneumatic barrel head carrying mechanism adapted to remove a barrel head from the

barrel head support and deposit it in proper position in the mouth of a barrel comprising an inner vertical tube having its upper end connected to a suitable source of air suction and provided with a side bend or elbow at its lower end, an inner short horizontal tube having a similar side bend or elbow at its inner end and pivotally bolted to the side bend or elbow of the vertical tube, an intermediate horizontal tube which is straight throughout and has its inner end in slidable telescopic connection with the outer portion of the inner short horizontal tube, an outer short horizontal tube provided at its outer end with a side bend or elbow and having its inner end in slidable telescopic connection with the outer portion of the straight intermediate horizontal tube, an outer short vertical tube having a side bend or elbow at its upper end pivotally bolted to the side bend or elbow of the outer short horizontal tube, a suction plate attached to the lower end of the outer short vertical tube and a slide mounted in the suction plate for closing the suction opening when desired; the side bends or elbows of the inner and outer vertical tubes being on the same side of and extending in the same direction and the side bends or elbows of the inner and outer horizontal tubes also being on the same side of and extending in the same direction but oppositely to the side bends or elbows of the inner and outer vertical tubes.

EDWIN F. BEUGLER.

Witnesses:

KATHERINE A. LANDIS,
CARL SCHRAMM.